

# 3-STATION PRE-CRIMP 90° SEAMER FIELD GUIDE

*Part# 50448*

9.14.23



Contact us at 1-888-343-0456 or online at [www.diroofseamers.com](http://www.diroofseamers.com)

D.I. Roof Seamers  
915 Highway 45  
Corinth, MS 38834

***\*READ COMPLETELY BEFORE OPERATION OF MACHINE OR TOOLS\****

Safety Regulations set forth by the Occupational Safety and Health Act, local, state, and/or federal agencies should always be adhered to.

# IMPORTANT INFORMATION

---

- This Roof Seamer has been set up for your specific panel profile. Never use this machine on any other panel or profile.
- Do not attempt to alter or modify the machine in any way.
- Follow all safety suggestions and warnings in this guide as well as those posted on the machine itself.
- It is recommended to “seam as you go”. In other words, seam the panels as they are being installed. This helps ensure that each panel is kept within module and installed correctly. If you cannot “seam as you go”, the order of seaming should follow the order of panel installation. The first panel installed should be the first panel seamed.
- **DO NOT run the roof seamer over hand-crimped sections of the panel. If you have hand-crimped ahead of the seamer, the machine must be stopped, moved, and restarted at the end of the hand-crimped portion.**
- Use only D.I. Roof Seamers hand crimpers.
- Use heightened attention when seaming the first few seams, until a pattern of properly seamed ribs is established. Then, follow the same process on similar seams. Again, use heightened attention if conditions change, such as different support types, clip spacing, or roof slope.
- For additional information, visit [www.diroofseamers.com](http://www.diroofseamers.com)

## **IMPORTANT**

### **Required extension cord size:**

Distance (FT)	0-100	100-200	200-300
Wire Gauge (AWG)	10	8	6

## SCAN OUR QR CODES FOR FURTHER INFORMATION



### Operational Videos



### D.I. Roof Seamers App

This is a single direction 90° Roof Seamer. It will complete the 90° (Single Lock) seam in a single pass. You simply engage it on the hand-crimped portion of the seam and apply power. It is important to remember to use extreme caution when reaching the edge of the roof. Stop and disengage the locking handles of the seamer while the wheels remain on the roof panel.

“Single Direction Seamer” means that the seamer must run from eave-to-ridge or ridge-to-eave, depending on the direction of panel installation. When this type of seamer reaches the end of the panel, it must be removed and transported back to the starting end to seam the next rib.

Do not run the seamer within 6” of the end of a panel without using extreme caution. Hand crimping in this area may be necessary if there are safety concerns or risks. Use your hand crimpers to finish any area that the seamer may not be able to complete such as the ridge cap area, end lap, or pitch change in the roof. Hand crimpers can be rented from D.I. Roof Seamers.

Your 3-Station Roof Seamer motor requires a 20-amp, 120-volt AC power supply. Poor performance and motor damage can result from the use of an improper power supply.

**Note:** Images used in this guide are for representation purposes only and may not be exact to your job.

## STEP 1

---

Before beginning, ensure that the panels are installed correctly and are free of all debris and contaminants such as sand, snow, excessive fluids, sealant/mastic, tools, extensions cords, etc. Keep a safety tether attached to the seamer anytime it is on the roof to prevent it from falling off. Failure to do so could result in machine damage, serious injury, and/or death.

**Note:** The machines tether point is not intended to arrest the machine during a free fall from the roof.

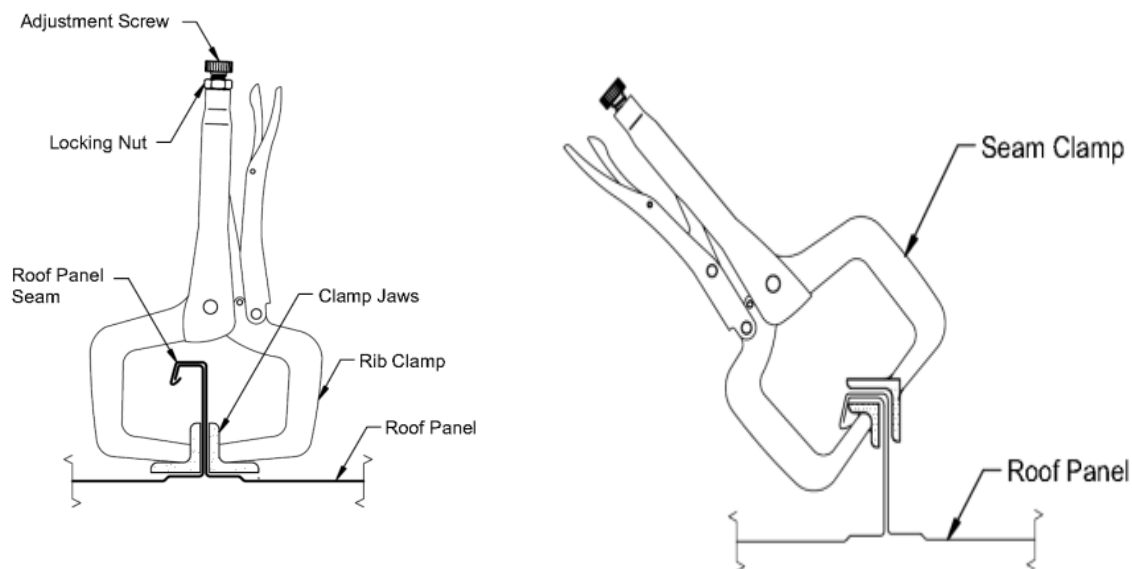

## STEP 2

---

Hand crimping at the beginning of each panel is required to start the seamer.

## CRIMPING PROCEDURE

---

**STEP #1-** Hand crimp the first 16" of each panel with the Hook Closure Hand Crimper.

**DO NOT OVER-CRIMP.  
THIS WILL DAMAGE THE  
CRIMPER(S).**

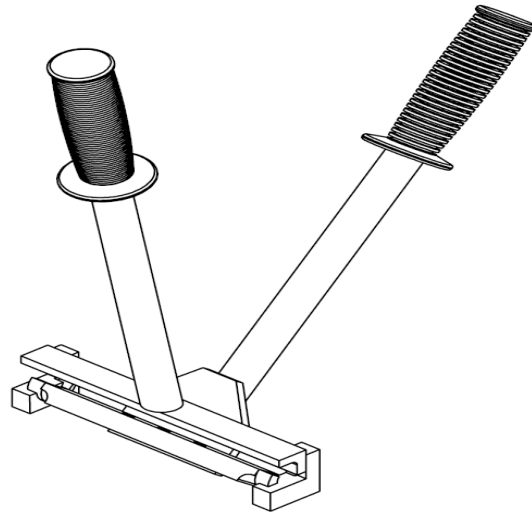

HOOK HAND CRIMPER (70527)

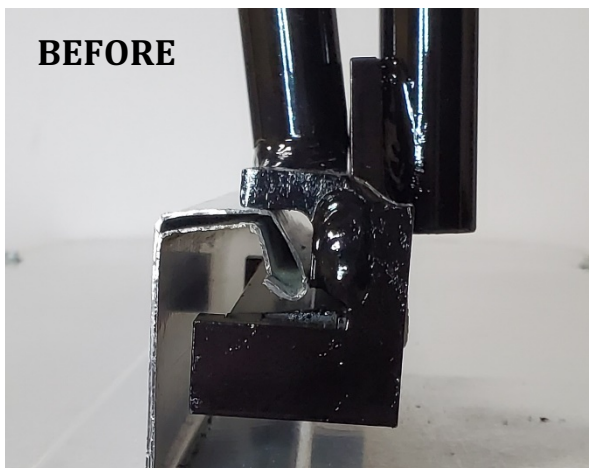

**STEP #2-** Crimp half (8") of the previous crimp with the 90° (Single Lock) Hand Crimpers.

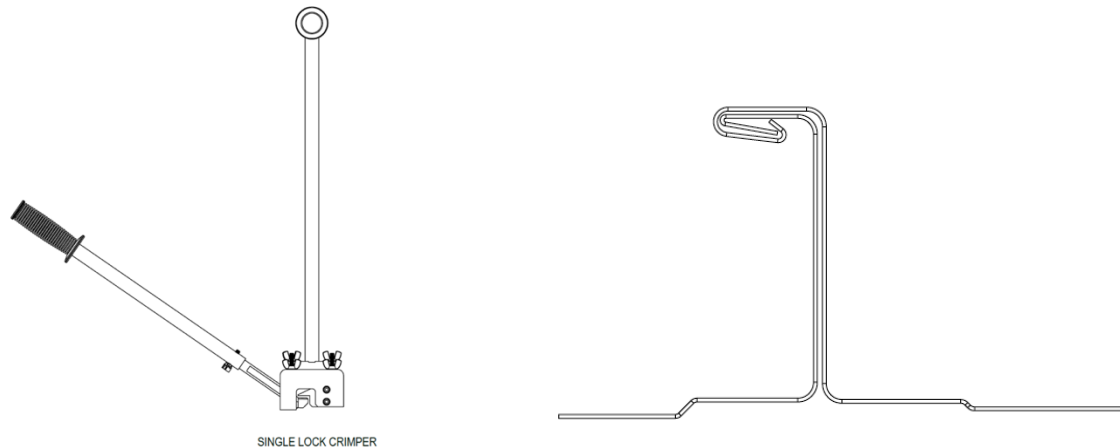

**DO NOT OVER-CRIMP. THIS WILL DAMAGE THE CRIMPER(S).**

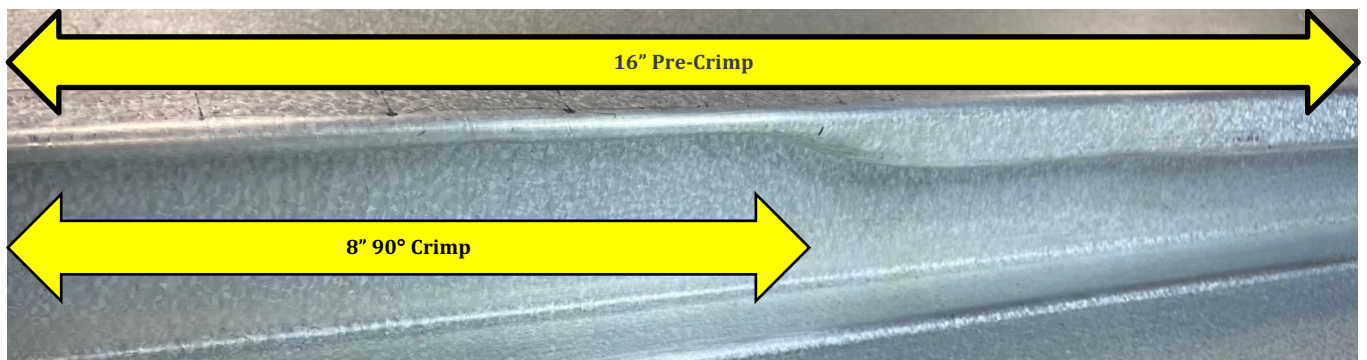

**STEP #3-** At end lap conditions, panels must be hand crimped only. Hand crimping the panel 8" at the end laps of the panel will help keep the panels in place during erection. Before reaching the hand-crimped end lap, the seamer must be stopped, moved, and restarted beyond the hand-crimped area.

## STEP 3

---

After hand crimping, place the machine on the crimped portion of the panel and engage the locking handles by pulling each handle out until it locks into place. Then, engage the red handle on the front of the machine in the “down” position. Make sure that the pre-crimp roller engages on the section of the panel that was “hook crimped” only, as shown below.

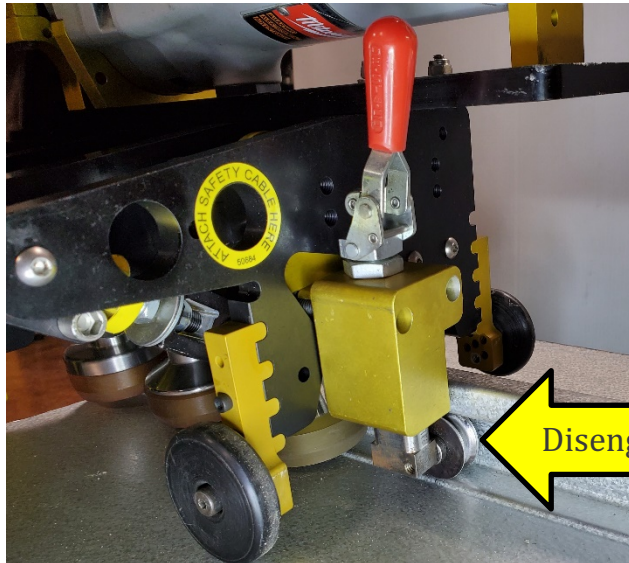

Disengaged

**DO NOT ENGAGE THE PRE-CRIMP ROLLER ON THE 90° HAND-CRIMPED AREA.**

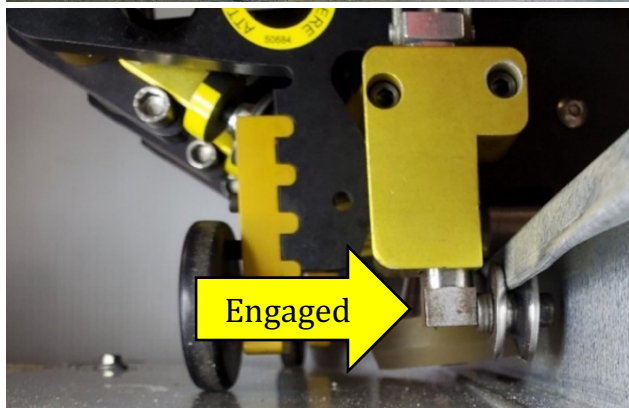

Engaged

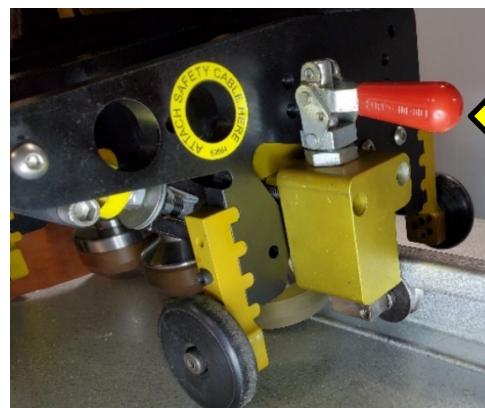

Engaged

# ROLLER PROGRESSION

---

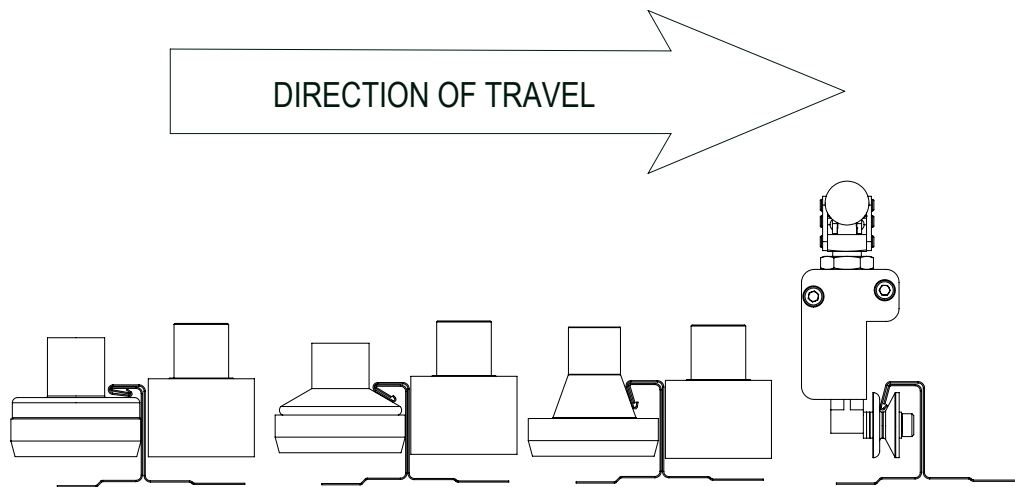

## STEP 4

---

Connect the power supply into the quick-release plug near the handle of the machine and turn the machine on. Run the seamer approximately 12" to ensure that you are receiving the desired seam. If there are any issues, stop immediately and **contact D.I. Technical Support at 1-888-343-0456.**



## STEP 5

---

Stop the machine near the end of the panel and remove it from the rib by pushing handles 1 thru 3 into the disengaged position. Disengage the pre-crimp mechanism and lift the seamer off the rib and transport it back to the starting end of the next rib to be seamed.



# MAINTENANCE REQUIREMENTS

---

- This machine requires daily cleaning. Additional cleaning may be required based on job site conditions. It is imperative that tooling is kept clean and free of debris.
- When not in use, always store your roof seamer in a dry place to prevent damage to the machine. **NEVER** operate it in inclement weather, such as rain, thunder, lightning, or snow.
- Each day that the seamer is to be used, ensure tooling bolts are tight to 25 ft-lbs. before the beginning of any seaming.
- If you need D.I. Technical Support, please **contact us at 1-888-343-0456.**

